

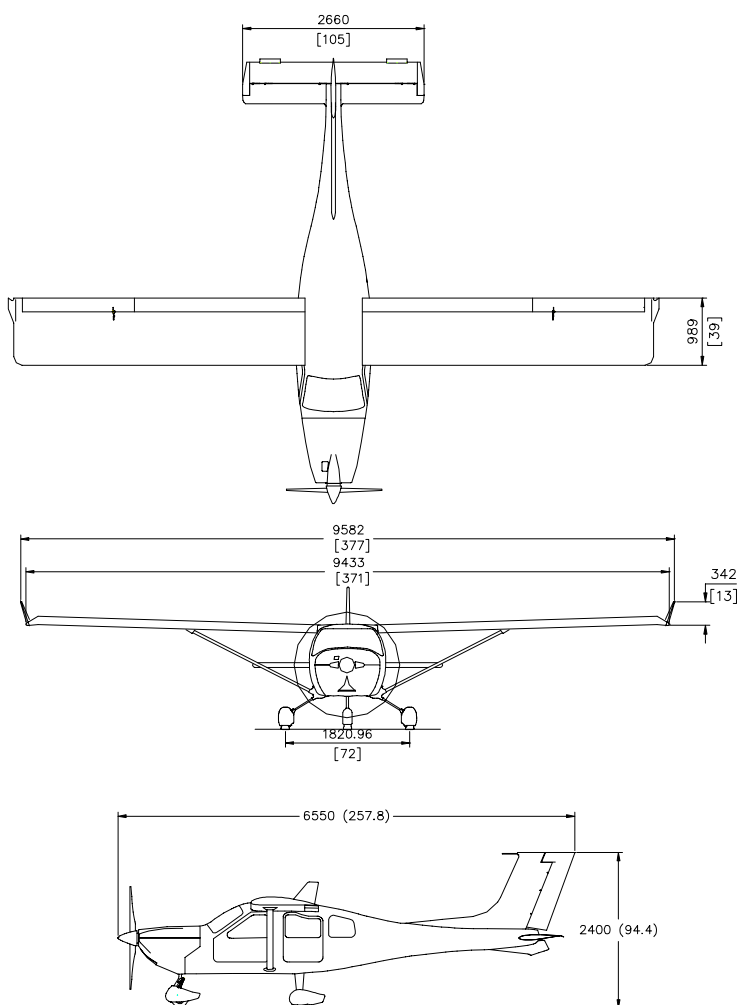

JABIRU J230 / J430



Engine	Jabiru 3300cc 120hp 6 cylinder, 4 stroke
Propeller	2 Blade Fixed Pitch Wooden/Composite 60" dia x 53" pitch
Height	2400mm (24.4")
Length	6550mm (257.8")
Width Tailplane	2660mm (104.7")
Cabin Width	1120mm (44.09")
Height	1090mm (42.9")
Wing Span	9433mm (30.9')
Wing Area	9.34sqm 100.5sq.ft
Wing Loading Gross (544kg)	11.92 lbs/sq.ft
Wing Loading Gross (700kg)	15.3 lbs/sq.ft
Aspect Ratio	9.5
<u>Speeds</u>	
Va (Max. Maneuver)	115 kts (132 mph)
Max Cruise	120 kts (138 mph)
Max. Straight & Level	135 kts (155 mph)
<u>Stall Speeds At 544KG</u>	
Vso (full flap)	39 kts (45 mph)
Vs1 (clean)	44 kts (51 mph)
Climb Rate (at sea level)	1000 ft/min
<u>Stall Speeds At 700KG</u>	
Vso (full flap)	45 kts (52 mph)
Vs1 (clean)	50 kts (57 mph)
Climb Rate (at sea level)	700 ft/min
Service Ceiling	15,000 ft
Empty Weight	340 kg (748 lbs)
Gross Weight	544 kg (1197 lbs)
Useable Load	204 kg (449 lbs)
Gross Weight	700 kg (1540 lbs)
Useable Load	360 kg (792 lbs)
<u>Structural Loading</u>	
Flight Load Factor	+ 3.8 – 1.9 G
Applied Loads	+6.8G -3.4G
54degC (129.2degF)	
Fuel Capacity (Usable)	135 lts (35.6 USgal)
Range (Nil Reserve)	800nm
Endurance (Nil Reserve)	6.7 hrs
Fuel Consumption at Cruise	20 lts/hr (6 USgal)
Glide Ratio	12:1
Crosswind Component	14 kts



Take Off Distance – @ 544kg (Ground-roll)	100m (328 ft)
Landing Distance – @ 544kg (Ground-roll)	180m (656 ft)
Take Off Distance – @ 700kg (Ground-roll)	150m (492 ft)
Landing Distance – @ 700kg (Ground-roll)	220m (820 ft)